

Purchase specification:
 The retention socket will be constructed using 1.4003 grade stainless steel to specification EN 10088-2:2005.
 The top plate will be 15,20 or 25mm thick (depending on the size of the socket) and welded to the upper body which will be 3mm thick. It will be powder coated black.
 The clamp plate will be clamped to the post using two A2/304 grade stainless steel, M8, M10 or M12 bolts (depending on the size of the socket). This should provide a grip to withstand 1400 Nm of torque. With the post installed, it will be able to withstand impact from a vehicle so that a new post can be quickly and easily installed without further excavation.
 The upper section of the socket shall be covered by grade 304 stainless steel cover plates secured with A2/304 grade stainless M5 steel screws.
 All functional components shall be easily serviceable after installation.

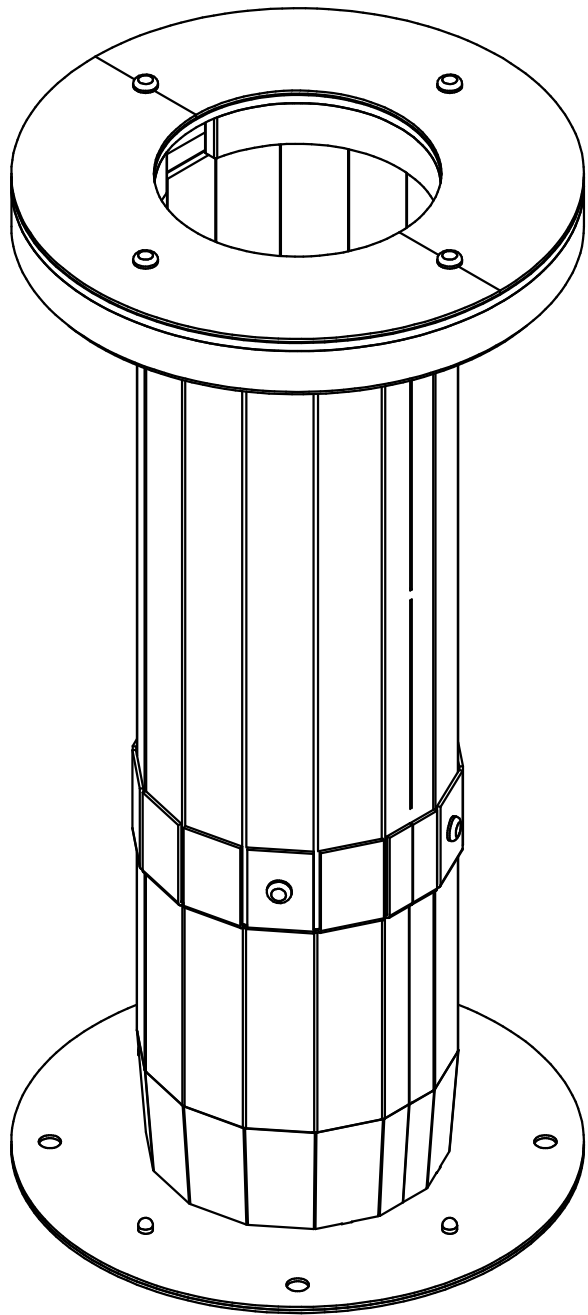

Standard Depths (A)
450mm
600mm
750mm
900mm

Different size Extension Sections are used to create the standard depths.
 Specific size Extension Sections can be manufactured to suit certain depth requirements.
 NOTE: 450mm is the minimum size the socket can be manufactured to.

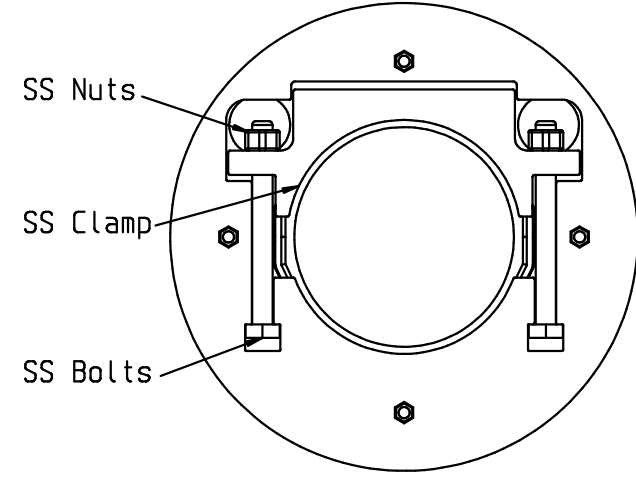
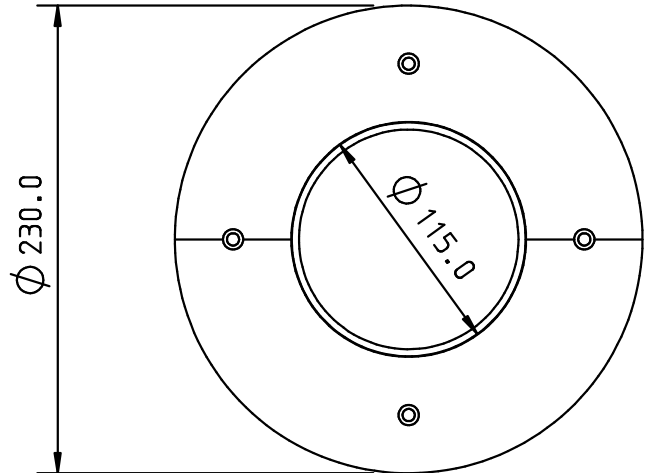
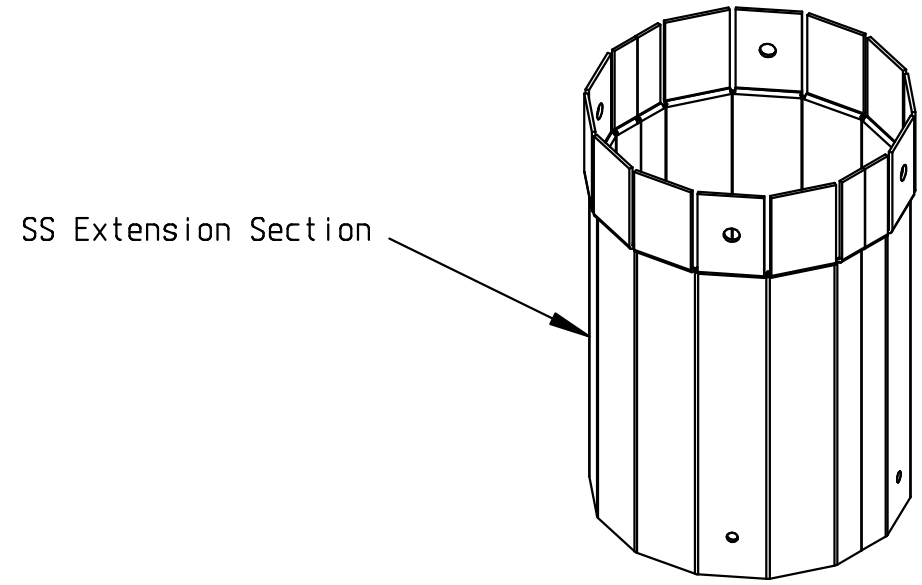
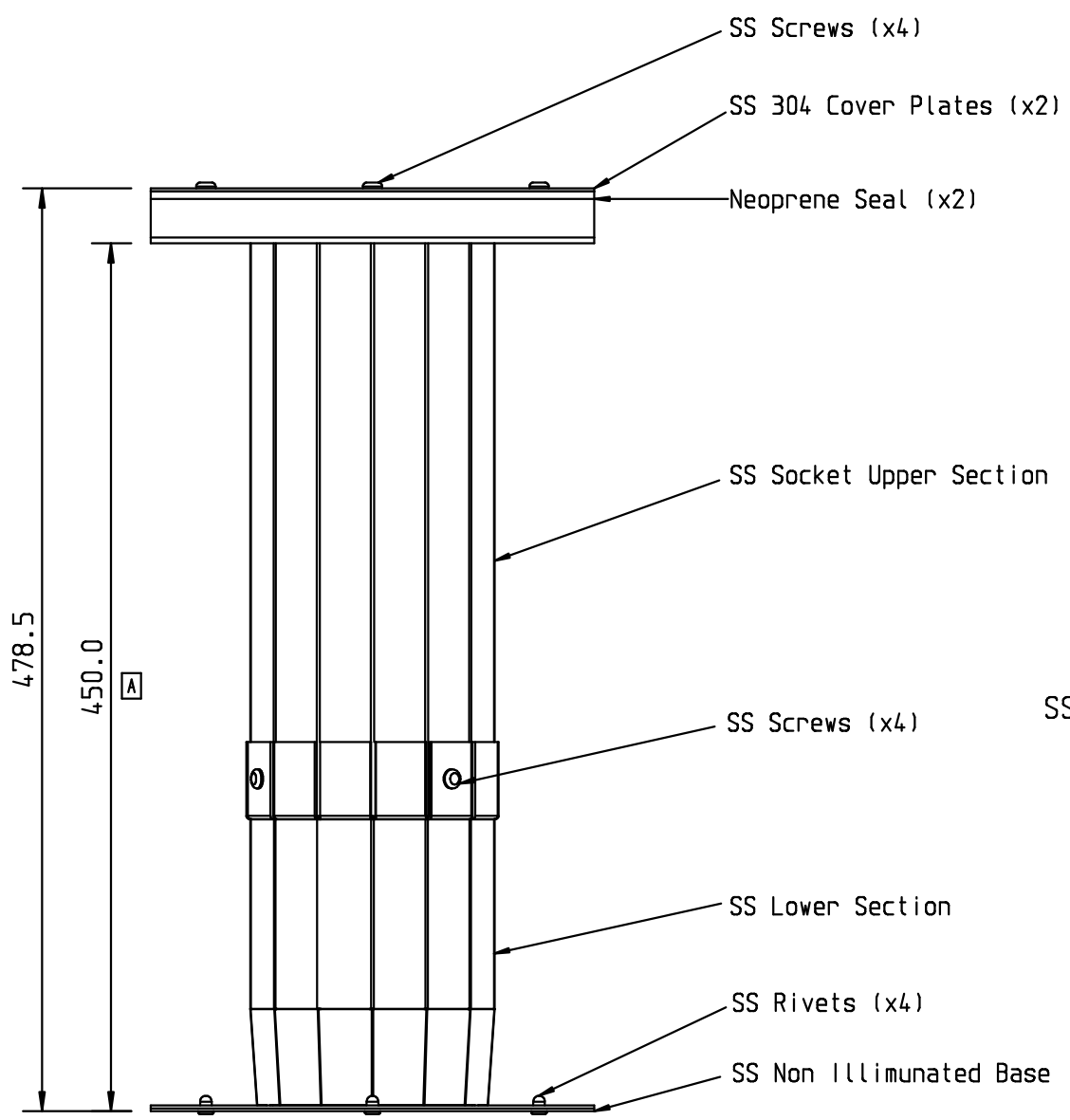

DRAWN	Josh Eastham	DATE	17 . 01 . 2018
CHECKED	Mark Blease	DATE	17 . 01 . 2018
APPROVED	Mark Blease	DATE	17 . 01 . 2018



COPYRIGHT IS STRICTLY RESERVED

TOLERANCES
 WHOLE NUMBERS +/- 0.5
 1 DECIMAL PLACE +/- 0.2
 HOLES +/- 0.15
 UNLESS OTHERWISE STATED

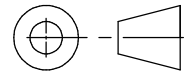

MATERIAL
 Stainless Steel

FINISH
 Powder Coated

TITLE Atlas 115 Non Illuminated Socket			
General Arrangement Drawing			
SCALE	DRAWING NO.	[SHEET]	ISSUE
NTS	S 9696	17	-

ISSUE	DATE	MOD. NO.	DRN

ALL OUTSIDE SIZES